

TAKE ONE PROGRAM ART SPECIFICATIONS

The TakeOne is a free standing printed piece that fits into a lucite or wire holder which is attached to the pole of the light unit.

As long as the printed piece fits into the holder, any style or layout is acceptable.*

The structure and the inside dimensions of the TakeOne holder are shown below:

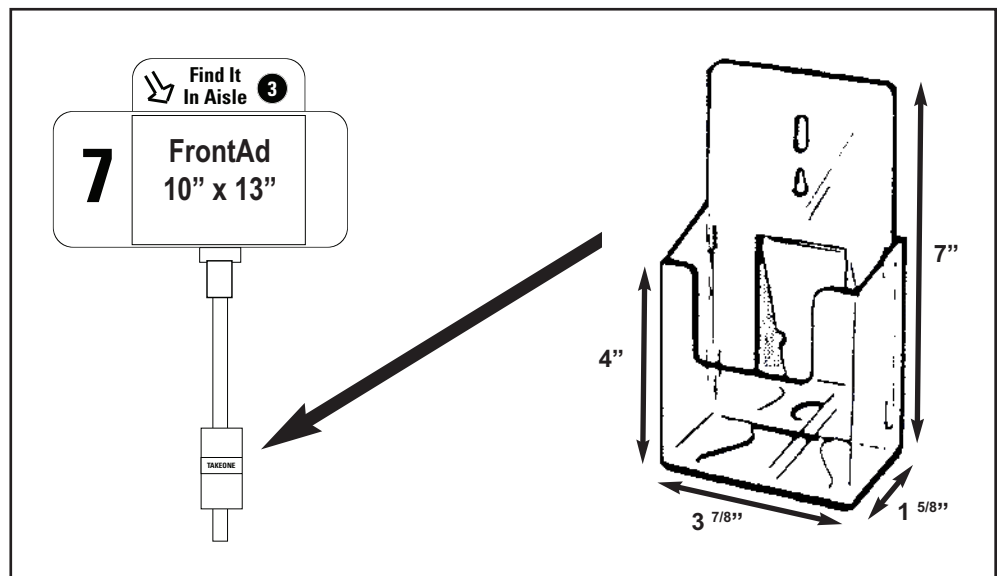

Mechanical Requirements

Printed offset using 4/color process inks.

All preliminary creative (color proofs) must be forwarded to the [FrontLine Production Traffic Manager at creativdepartment@frontmark.com](mailto:creativdepartment@frontmark.com) for approval, prior to delivery of final artwork.

Mac files are required for all FrontLine programs. IBM/PC formats can be converted for an additional charge. Accepted Mac formatted media includes Zip 100 & 250, CD-R, CD-RW, 3.5 floppy and DVD. All current Mac programs are supported but Illustrator, Quark Xpress, PhotoShop and InDesign are preferred.

When submitting art on disk, all documents should include all working (layered) files, supporting fonts, illustrations and scans. All submitted fonts should be Postscript in nature. Do not use 'True Type' fonts or stylized fonts in Quark. Illustrator files should have all fonts converted to outlines.

Send a disk directory with laser or color proof for each ad. All images and or files should be 300DPI and converted to CMYK before sending. For further technical information, contact FrontLine Production Traffic Manager at creativdepartment@frontmark.com.

Minimum trim size of the Take-One is 3⁷/₈ x 4 and bleeds are ok.

Maximum trim size of the Take-One is 3⁷/₈ x 9 and bleeds are ok.

4c Screen: 150 Line Screen

*All TakeOne Riser Cards to follow the same width (and printing) specifications as TakeOne and should extend 3" above the actual TakeOne brochure.

All printed TakeOnes must be bundled in panels (1 Panel= 2 sides) as follows:

1-2 Panels	—	60lb coated stock	—	Bundles of 125
3-4 Panels	—	50lb coated stock	—	Bundles of 100

Note: Send Preliminary color proof to creativdepartment@frontmark.com